

MI heating cable|MI heat trace cable uses single or multiple alloy heating wires as heat source, high purity, high temperature, fused crystalline magnesium oxide as thermal insulator, seamless continuous stainless steel or copper tube as sheath, adopts Manufactured by special production technology. The stainless steel sheathed mineral insulated heating cable can meet the needs of high temperature conditions and high heating power (up to 269W/m). The armored mineral insulated heating cable is suitable for antifreeze and heat preservation and heating of the process medium in the industrial or construction field. Especially for pipelines that require high output power or need to withstand high-temperature steam purging, MI mineral insulated heating cables can show excellent characteristics in environments that require anti-corrosion and explosion-proof.

MI heating cable|MI heat trace cable structure

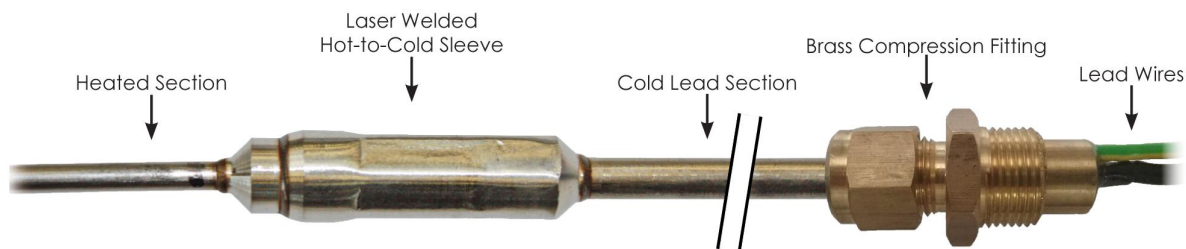

Single conductor high temperature MI mineral insulated heating cable

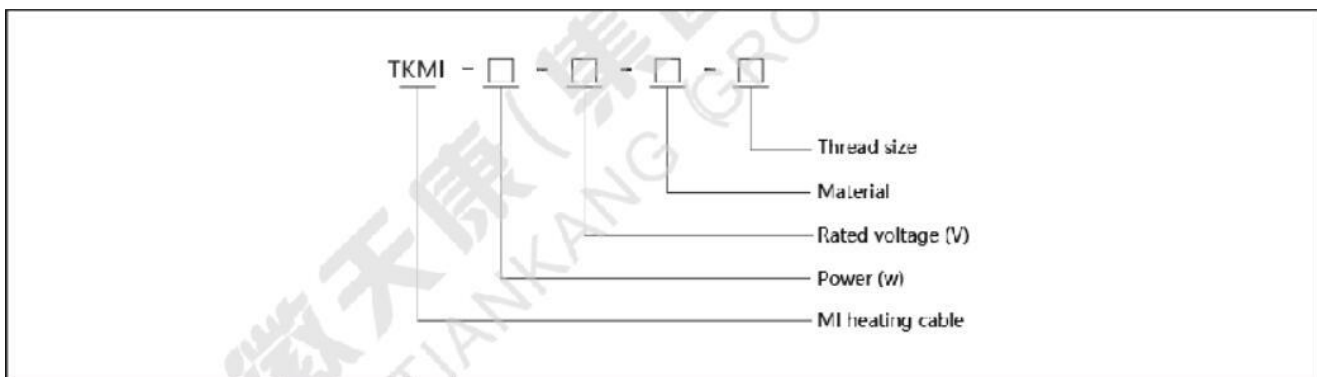

Voltage: 110V ~ 1100V

Withstand voltage: 2000V

Insulation: 500M Ω

Power: 2 ~ 20KW

Maximum length: 1000m

Maximum temperature resistance: 800 $^{\circ}$ C

Uses: deep well oil production heating, petrochemical pipeline heat tracing insulation, tank body heat tracing insulation, railway track snow melting and ice melting, power grid tower snow melting and ice melting

Super long high-power high-temperature MI mineral insulated heating cable



Voltage: 110V ~ 1100V

Withstand voltage: 2000V

Insulation: 500M Ω

Power: 2 ~ 50KW

Maximum length: 2000m

Maximum temperature resistance: 800°C

Uses: deep well oil production heating, petrochemical pipeline heat tracing insulation, tank body heat tracing insulation, railway track snow melting and ice melting, power grid tower snow melting and ice melting

Double conductor high temperature MI mineral insulated heating cable



Voltage: 110V ~ 1100V

Withstand voltage: 2000V

Insulation: 500MΩ

Power: 2 ~ 20KW

Maximum length: 1000m

Maximum temperature resistance: 800°C

Uses: deep well oil production heating, petrochemical pipeline heat tracing insulation, tank body heat tracing insulation, railway track snow melting and ice melting, power grid tower snow melting and ice melting

MI heating cable|MI heat trace cable Performance parameter

Technical parameter	Nickel chromium stainless steel sleeve structure	825Alloy sleeve structure
Heating power (W/m)	50-250	50-250
Maximum surface temperature (°C)	650	800
Maximum operating temperature (°C)	450	550
external	Single core	Ø3.5-6.5
		Ø3.5-6.5

diameter (mm)			
	Double core	Ø5.5-11	Ø5.5-11
Material (mm)	Conductive core wire	Nickel chromium alloy	Nickel chromium alloy
	Insulating material	Magnesia powder	Magnesia powder
	Metal sheath	stainless steel	825alloy

MI heating cable|MI heat trace cable Features

Since MI mineral insulated heating cable is made of metal and inorganic insulating materials, it has significantly different advantages than other heating cables or heating cables made of plastic insulation. Due to its special structure, it has the following characteristics:

1. Because its components are all composed of non-combustible inorganic substances, the product is fireproof, flame-retardant, and does not generate toxic gases. Because the heating cable has a reliable metal tube seal and good grounding, it is especially suitable for various explosion-proof places.
2. Because the magnesium oxide insulating material can remain stable when the temperature is as high as 550°C. Therefore, the operating temperature limit of the heating cable itself is the highest temperature that the core and metal outer sheath can withstand.
3. The insulation layer of the product, magnesium oxide, is an inorganic substance, and the core and outer sheath are both made of metal, so the aging problem is fundamentally solved, and the service life of the heating cable is greatly extended. The service life can reach several decades under specified conditions.
4. The product adopts different outer sleeves, which can withstand the erosion of oil solvents and most acids, and has good chemical stability.
5. Good mechanical performance. Because of its strong structure, it can withstand twisting, squeezing, bending, pulling, friction and general heavy handling.
6. Because the heating method of the heating cable belongs to a series of resistance electric heating elements, the heating is uniform and the temperature difference over the entire length is extremely small
7. The heating power is large, generally 30~250W/m. The heating cable will not be frozen due to the stop of steam supply like the steam heating pipeline. The power supply can be turned on when needed, without frequent maintenance.

8. Low temperature resistance, no brittle break during construction at low temperature, easy for winter construction and maintenance

9. It is resistant to solar radiation and nuclear radiation, and the working temperature is high. 250°C, 400°C, 600°C.

The heating and heat preservation technology of **MI heating cable|MI heat trace cable** is a new method for heating and heat preservation of metal pipes developed in the market in recent years. It is a new technology and new process for heating and heat preservation of heat transmission pipelines in large petrochemical enterprises. This heating technology is suitable for various long (800-1000m), medium and short distance metal pipeline heating and heat tracing insulation projects.

Chemical industry: heating pipes, containers, tanks, etc., requiring products to maintain the required process temperature during processing;

Petroleum industry: internal and external crude oil pipelines, valves, installations, oil tank heating;

Power stations: oil pipelines and containers of oil-fired power stations for heating; antifreeze heating for pipelines of hydropower stations, and preheating of water pipes, valves and reactor sodium loops in nuclear power stations;

Natural gas industry: gas tank water sealing heating, pipeline valve and device heating, catalytic reactor gas heating, natural gas quality control heating, etc.;

Construction industry: rapid drying and heating of cement, pre-drying of refractory bricks, heating and heating of houses and buildings;

Shipbuilding industry: anti-condensation heating on decks and cabins;

Urban construction: deicing and heating of roads, slopes, steps, tunnel pavements, etc.; snow melting and deicing in sports stadiums, squares, airport runways, and anti-icing places such as roofs, eaves, and rain leakage.