

Alloy 825 MI heating cable|Alloy 825 high temperature MI heat trace

cable available for up to 700°C exposure temperatures and typically up to 270W /m output power. Mineral-insulated (MI) heating cables are available in single and dual conductor configurations and have a very wide range of resistances. The use of dual conductor MI heating cables can reduce the total installation cost and simplify installation, especially for small pipes and instrument pipes. Mineral insulation (MI) alloy 825 series heating cables are suitable for use in hazardous areas. They are designed for antifreeze and temperature maintenance applications of pipes, tanks and other equipment. With the ideal combination of rugged, high temperature and corrosion resistance, the MI heating cable can be used in a variety of thermal applications, especially in applications with high power requirements as well as in applications with temperatures over 200°F.

Alloy 825 MI heating cable structure

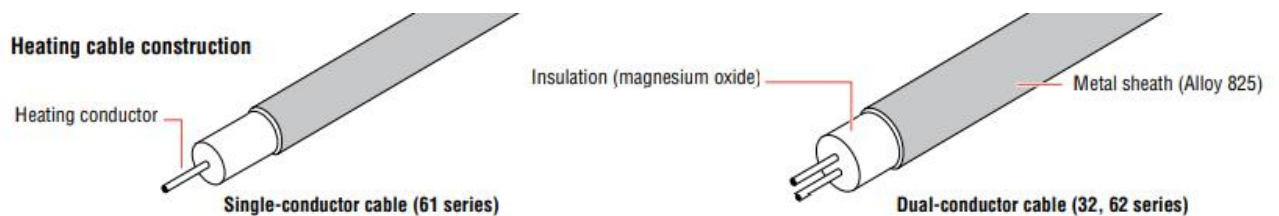

Alloy 825 MI heating cable Specifications

Voltage Rating 600 V

Conductor Material Nickel

Construction Mineral Insulated Cable

Insulation Material Magnesium Oxide

Sheath Material Alloy 825

Flame Retardant In Accordance with EN 60332-3-24

Max Operating Temperature 1238 °F

Max Exposure Temperature 2200°F

Alloy 825 MI heating cable install the system

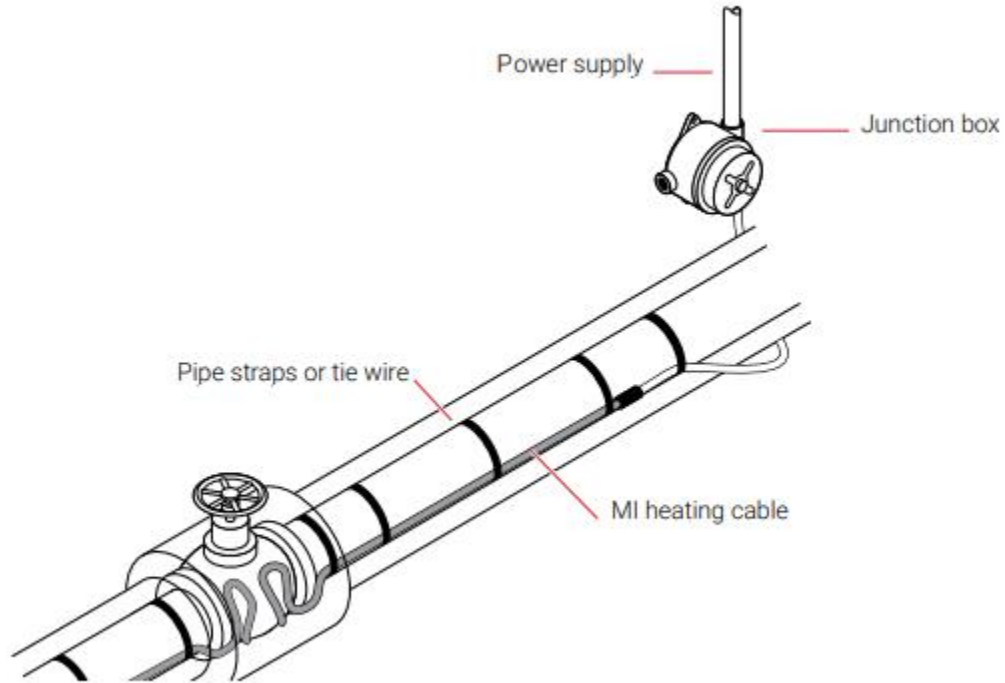

Typical mineral insulated heating cable system

Alloy 825 high temperature MI heat trace cable Performance parameter

Technical parameter		Nickel chromium stainless steel sleeve structure	825Alloy sleeve structure
Heating power (W/m)		50-250	50-250
Maximum surface temperature (°C)		650	800
Maximum operating temperature (°C)		450	550
external diameter (mm)	Single core	Ø3.5-6.5	Ø3.5-6.5

	Double core	Ø5.5-11	Ø5.5-11
Material (mm)	Conductive core wire	Nickel chromium alloy	Nickel chromium alloy
	Insulating material	Magnesia powder	Magnesia powder
	Metal sheath	stainless steel	825alloy

Alloy 825 high temperature MI heat trace cable Features

Since MI mineral insulated heating cable is made of metal and inorganic insulating materials, it has significantly different advantages than other heating cables or heating cables made of plastic insulation. Due to its special structure, it has the following characteristics:

1. Because its components are all composed of non-combustible inorganic substances, the product is fireproof, flame-retardant, and does not generate toxic gases. Because the heating cable has a reliable metal tube seal and good grounding, it is especially suitable for various explosion-proof places.
2. Because the magnesium oxide insulating material can remain stable when the temperature is as high as 550°C. Therefore, the operating temperature limit of the heating cable itself is the highest temperature that the core and metal outer sheath can withstand.
3. The insulation layer of the product, magnesium oxide, is an inorganic substance, and the core and outer sheath are both made of metal, so the aging problem is fundamentally solved, and the service life of the heating cable is greatly extended. The service life can reach several decades under specified conditions.
4. The product adopts different outer sleeves, which can withstand the erosion of oil solvents and most acids, and has good chemical stability.
5. Good mechanical performance. Because of its strong structure, it can withstand twisting, squeezing, bending, pulling, friction and general heavy handling.
6. Because the heating method of the heating cable belongs to a series of resistance electric heating elements, the heating is uniform and the temperature difference over the entire length is extremely small
7. The heating power is large, generally 30~250W/m. The heating cable will not be frozen due to the stop of steam supply like the steam heating pipeline.

The power supply can be turned on when needed, without frequent maintenance.

8. Low temperature resistance, no brittle break during construction at low temperature, easy for winter construction and maintenance